

CURC

COAL UTILIZATION RESEARCH COUNCILSM

Carbon Capture and Storage: A Technology Solution for Continued Coal Use in a Carbon Constrained World

Congressional Briefing

May 22, 2008

562 Dirksen Senate Office Building

WHAT IS THE STATE OF CCS TECHNOLOGY DEVELOPMENT?

**Dr. Edward Levy
Director, Energy Research Center
Lehigh University**

**CURC Congressional Briefing
on Carbon Capture and Storage**

May 22, 2008

ELECTRICITY FROM COAL

TWO MAIN APPROACHES:

- **Pulverized Coal Steam Power Plant**
- **Integrated Gasification Combined Cycle (IGCC)**

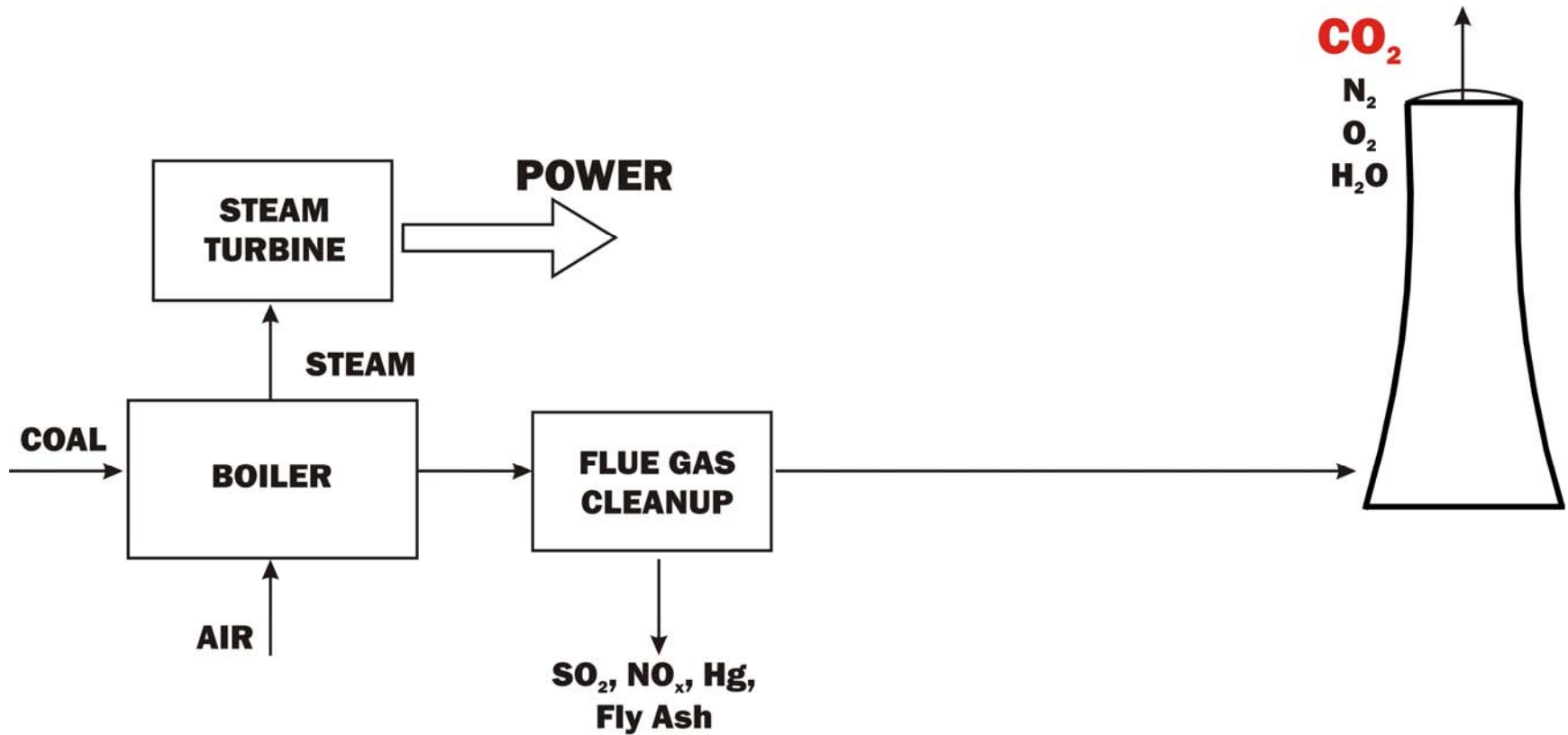

CONVENTIONAL STEAM POWER PLANT

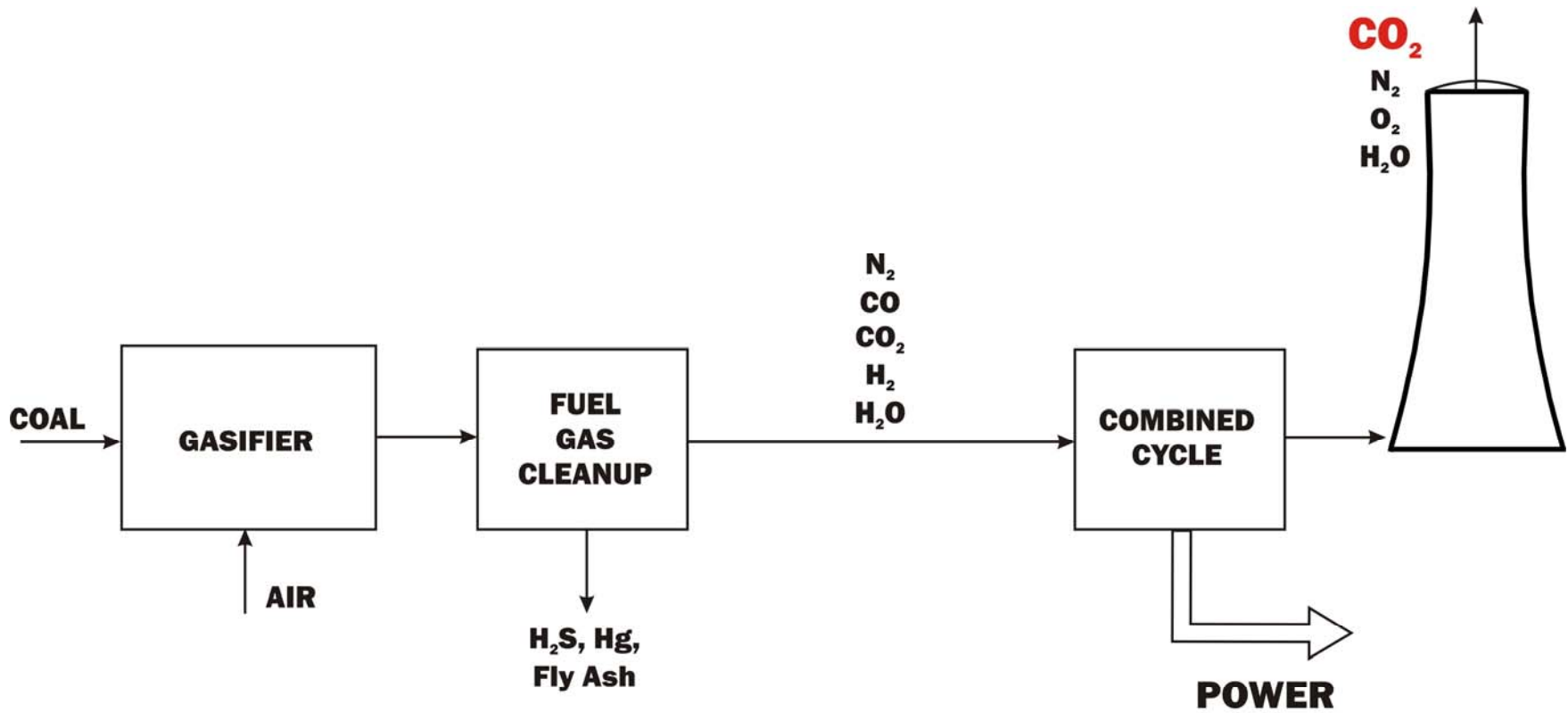

INTEGRATED GASIFICATION COMBINED CYCLE (IGCC)

METHODS TO REDUCE CO₂ EMISSIONS FROM COAL USE

- **Increase power plant efficiency**
Higher efficiency → Lower CO₂ emissions
- **Capture and sequester CO₂ before it is emitted from the power plant**

INCREASE EFFICIENCY OF EXISTING PLANTS

- **Optimize process conditions using advanced sensors and controls**
- **Install equipment upgrades**
- **Employ more aggressive maintenance practice**

This can be done now!!

INCREASE EFFICIENCY OF EXISTING PLANTS

- **CO₂ reduction levels up to 16% are possible for some existing units**
- **An overall reduction in fleet CO₂ emissions of at least 5% appears practical**

BUILD NEW PLANTS WITH HIGHER EFFICIENCIES

- **IGCC technology ... has inherently high efficiency**
- **High efficiency ultrasupercritical steam power plants**

**The target is 30% lower CO₂ emissions
than from the average
existing pulverized coal unit**

CARBON CAPTURE METHODS

CARBON CAPTURE METHODS

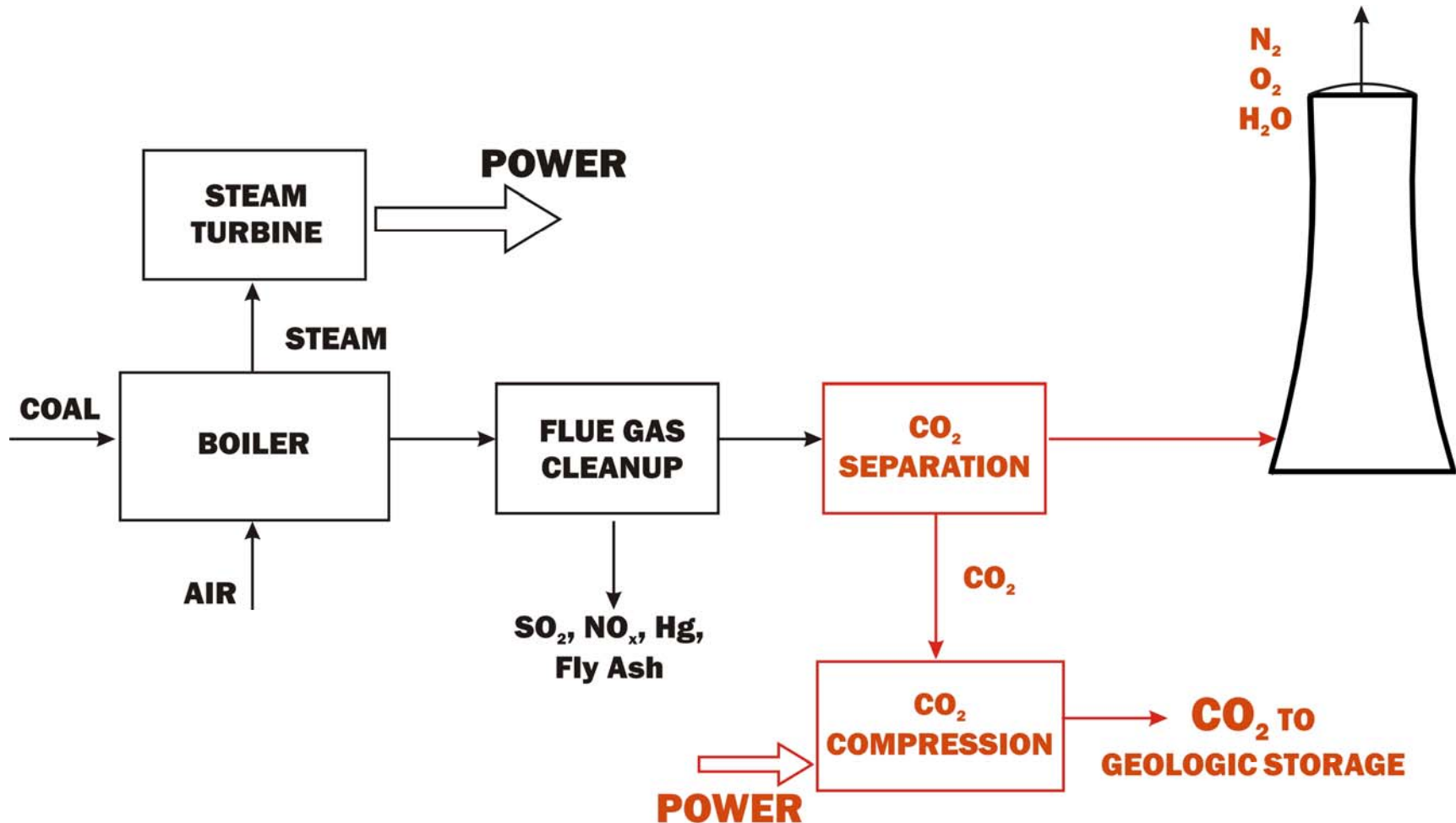

STEAM POWER PLANT WITH POST-COMBUSTION CAPTURE

CARBON CAPTURE METHODS

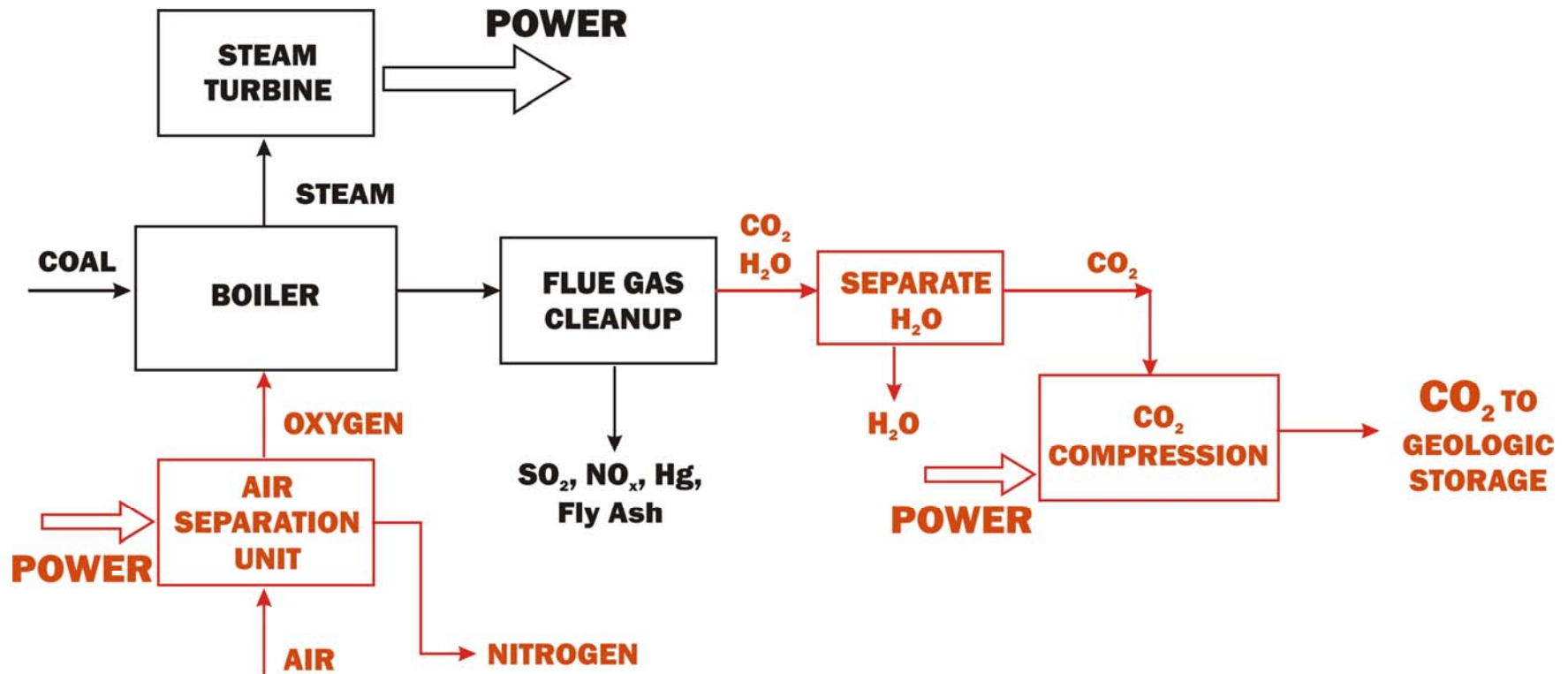

STEAM POWER PLANT WITH OXY-COMBUSTION

CARBON CAPTURE METHODS

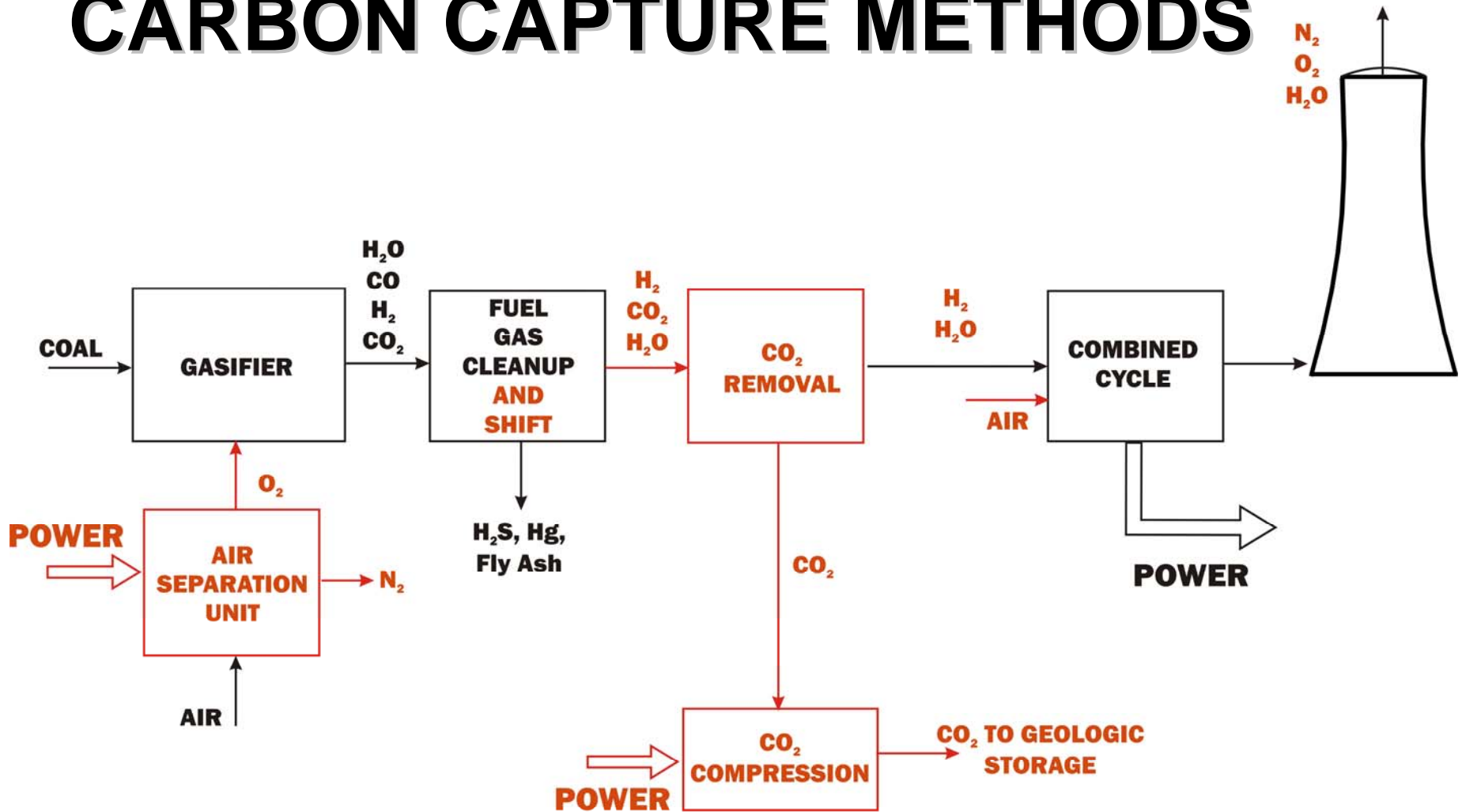

INTEGRATED GASIFICATION COMBINED CYCLE (IGCC) WITH CO₂ CAPTURE

FIRST GENERATION CARBON CAPTURE WILL BE EXPENSIVE !!

- **Present-generation capture systems would increase cost of electricity by 60 to 90% when compared to conventional pulverized coal power generation technology.**
- **In addition, parasitic power required to operate CCS systems would result in need for additional electrical generation capacity.**

FIRST GENERATION CARBON CAPTURE WILL BE EXPENSIVE!!

(continued)

Some improvements are “learn by doing”; others require development of new processes, components or materials

Technology Advances Are Starting to Emerge

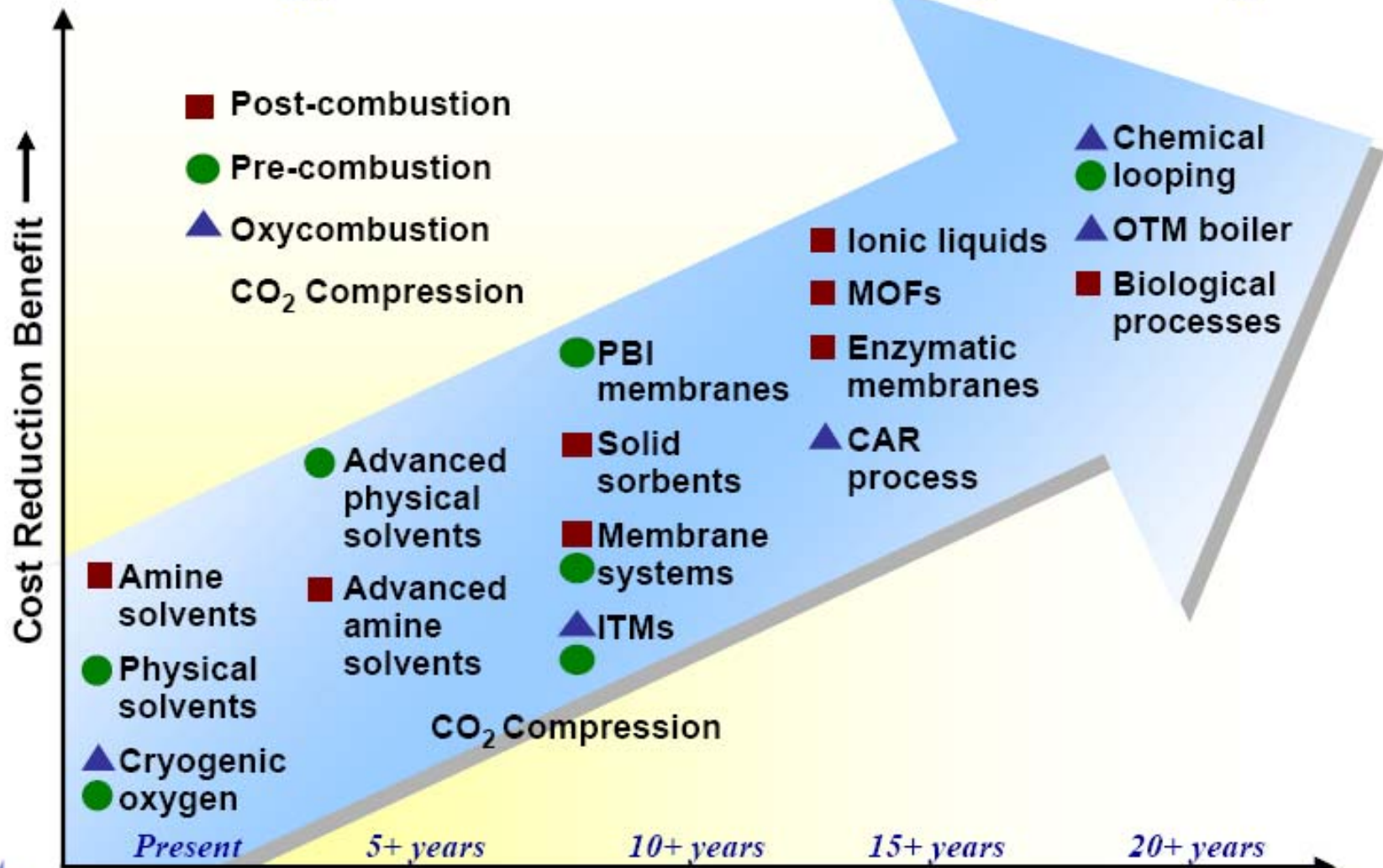

Time to Commercialization
OFFICE OF FOSSIL ENERGY



FIRST GENERATION CARBON CAPTURE WILL BE EXPENSIVE!!

(continued)

- **With continued RD&D, the costs for both advanced IGCC and advanced PC plants with and without CO₂ capture are expected to go down**

CO₂ SEQUESTRATION

WHAT WILL WE DO WITH THE CAPTURED CO₂?

- **ENHANCED OIL RECOVERY**
- **COAL BED METHANE RECOVERY**
- **INJECTION INTO DEEP SALINE AQUIFERS**

Overview of Geological Storage Options

- 1 Depleted oil and gas reservoirs
- 2 Use of CO₂ in enhanced oil recovery
- 3 Deep saline formations
- 4 Use of CO₂ in enhanced coal bed methane recovery

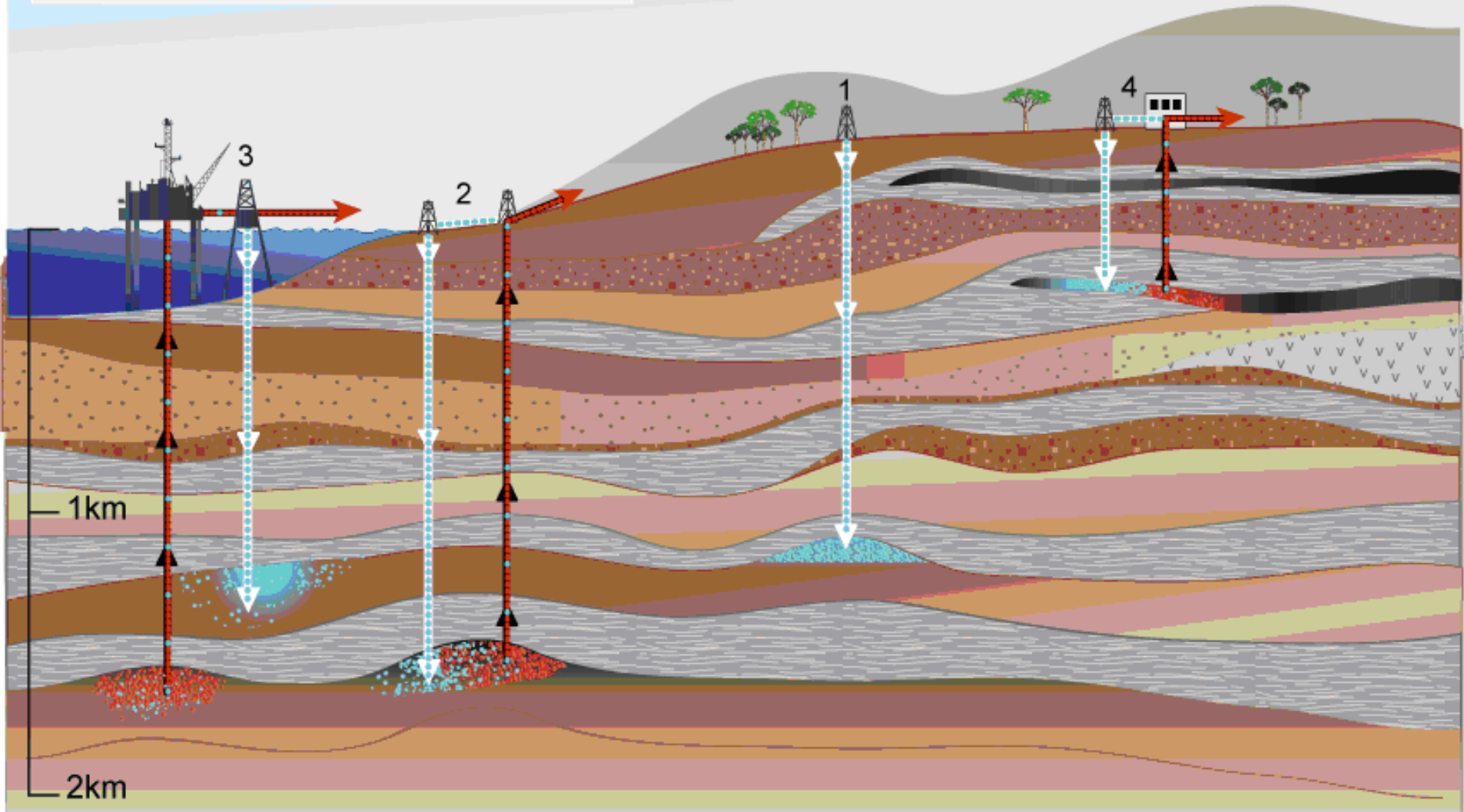

SUBSTANTIAL CO₂ STORAGE OPPORTUNITIES IN THE U.S.

U.S. emits ~ 6 GT CO₂/yr from all sources and 2 GT from coal-fired power plants

North American CO₂ Storage Potential (Giga Tons)

<u>Type</u>	<u>Low</u>	<u>High</u>
Saline	969	3,223
Unmineable Coal Seams	70	97
Oil & Gas Fields	82	83

CO₂ GEOLOGIC STORAGE: ISSUES



- **Decades of commercial experience with enhanced oil recovery**
- **However, this has involved much smaller amounts of CO₂ than will be needed for coal-fired power plants**
- **No experience with saline aquifers**
- **DOE has aggressive program to inject CO₂ into different types of geologic formations**

Large Scale Field Tests Injection Schedule



Injection Schedule

- 2008 Injection Scheduled
- 2009 Injection Scheduled
- 2010 Injection Scheduled
- 2011 Injection Scheduled

	Partnership	Geologic Province	Formation Type
1		Triassic Nugget Sandstone/ Moxa Arch	Saline
2		Mt. Simon Sandstone	Saline
3		Mt. Simon Sandstone	Saline
4		Williston Basin Carbonate	Oil Bearing
5		Devonian Age Carbonate Rock	Saline
6		Lower Tuscalooga Formation Massive Sand Unit	Saline
7			
8		Regional Jurassic and Older Formations	Saline
9		San Joaquin Basin	Saline



CO₂ GEOLOGIC STORAGE: ISSUES

- **Legal and institutional questions (such as liability and permitting) need to be resolved**

TECHNOLOGY STATUS IN U.S.

- **Pulverized coal with post-combustion CO₂ capture or oxycombustion**
 - > **Several small pilot scale tests in progress**
 - > **Larger scale demonstrations being planned**

TECHNOLOGY STATUS IN U.S.

- **IGCC with carbon capture**
 - > **Some existing non-power gasification plants use CO₂ capture today**
 - > **Several large-scale IGCC demonstration plants with CO₂ capture being explored**

TECHNOLOGY STATUS IN U.S.

- **Geologic Sequestration**
 - > **Enhanced oil and gas recovery ... (Practiced commercially)**
 - > **Storage in saline aquifers and in unmineable coal seams ... DOE is funding field tests**
 - > **Storage tests at power plant scale needed to reduce technical uncertainties**

WHAT'S NEEDED TO REDUCE CO₂ EMISSIONS NOW AND IN THE FUTURE?

- **Efficiency improvements to both the existing fleet and new coal plants to minimize CO₂ emissions**
- **Cost reductions and efficiency improvements for capture “systems”**
- **Large scale testing of storage of CO₂ in deep saline reservoirs:**
 - **Eliminate permitting uncertainty**
 - **Address liability issues**

WHAT'S NEEDED TO REDUCE CO₂ EMISSIONS NOW AND IN THE FUTURE?

- **Integrated capture and storage demonstrations**
- **Large-scale deployment of successful technologies**

CONTACT INFORMATION

Dr. Edward Levy
Energy Research Center
Lehigh University
E-mail: ekl0@lehigh.edu
Telephone: (610) 758-4090